



SURFCOM NEX series

Surface and contour measurement in a single instrument

The SURFCOM NEX series

A major step in automation

Rapid measurement of different workpieces even with temperature fluctuations





- Measurement of surface finish and contour – sensors can be combined as required

With the new, versatile hybrid detectors, SURFCOM NEX covers a measuring range twice as large as conventional instruments. This measuring instrument is suitable for measuring the surface quality and contour of inclined, corrugated, and curved surfaces in a single procedure. The special stylus can be swapped in and out at any stage depending on the workpiece.

- Rapid preparation and measurement thanks to the fastest drive in its class and a wide range of hybrid sensors

The significantly improved drive speed ensures a faster feed motion in manual mode. Furthermore, it enables the creation of CNC programmes and the performance of CNC measurements. This increases the efficiency of the entire inspection process. The hybrid detector with its large measuring range allows surface finish and contour to be measured in a single step. In addition, there is no need to precisely align the sensor prior to measuring inclined or curved surfaces. This saves time and effort in the measurement process.

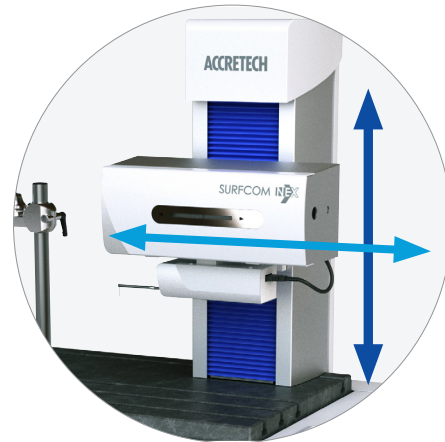

- The only measuring instrument with linear motor drive that performs measurements that are almost vibration-free and can be used at $20 \pm 5 \text{ }^\circ\text{C}$

SURFCOM NEX uses ACCRETECH's patented linear motor drive. The extremely low-vibration drive reduces vibration-related noise and ensures highly accurate measurement results. Real-time correction of temperature changes ensures accuracy over a wide temperature range of 15 to 25 °C. This enables reliable measurement results even with temperature fluctuations.

Rapid drive for shorter cycle times

Innovative column and feed unit with linear drive ensure significantly higher traversing speed

Traversing speeds:

	Conventional	NEW	
X-axis	60 mm/s	100 mm/s	1.6 times faster*
C-axis	10 mm/s	50 mm/s	5 times faster*

* than conventional instruments



New, faster coupling and brake mechanism

Patented

The vertical movement, which is adapted to the load of the drive, optimises the reduction ratio, thereby increasing the maximum acceleration and speed.



More efficient continuous measurement of multiple workpieces using automation or workpiece handling systems

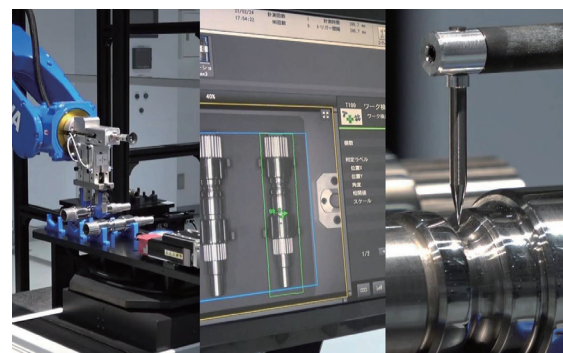

ACCURETECH

SURFCOM **NEX**

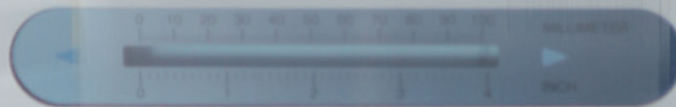

HYBRID SYSTEM
New & Well Technology

Innovative hybrid sensor with large measuring range and high resolution

Surface quality and contour can be measured in a single step.

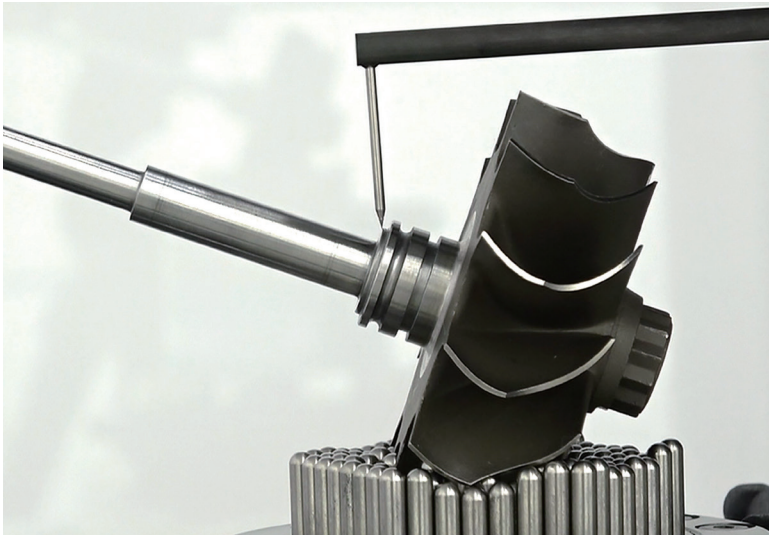
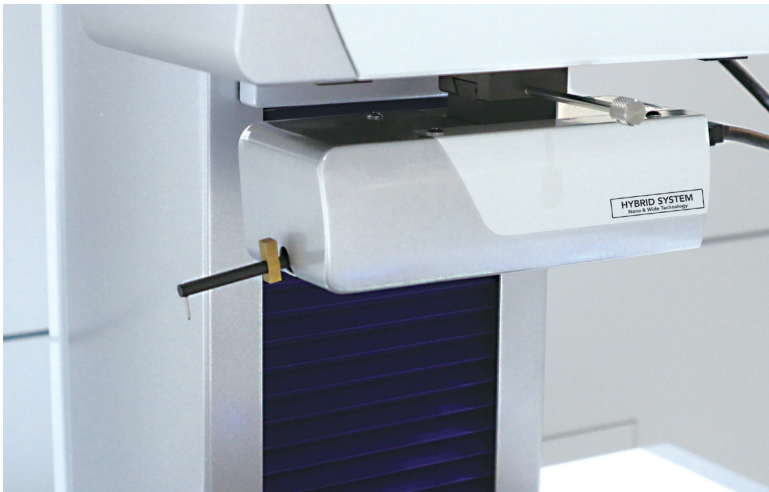

Z-axis measuring range

Conventional	New hybrid sensor	
5 mm	13 mm When using stylus with LH=50 mm	2.6 times larger*
	26 mm When using stylus with LH=50 mm	5.2 times larger*

*than conventional measuring instruments

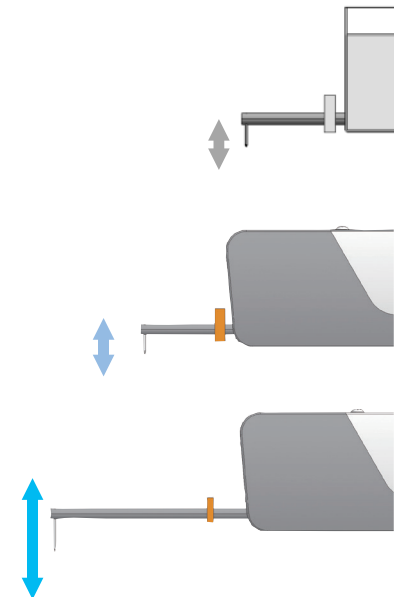

High resolution even with large measuring range

With conventional hybrid and roughness detectors, the measuring range needs to be reduced for high-resolution measurements, e.g. to 0.5 mm or 0.05 mm, even if a measuring range of up to 5 mm is supported. With the SURFCOM NEX hybrid detector, there is no need to adjust the measuring range. This sensor offers high resolution in a measuring range of 13 or 26 mm without any adjustment.

Resolution (full measuring range)	Measuring range Z-axis
0.9 Nm	13 mm When using stylus with LH=50 mm
1.8 Nm	26 mm When using stylus with LH=50 mm

Large contour measuring range

By changing to a special contour stylus, it is possible to further extend the Z-axis measuring range. Only the stylus – instead of the entire sensor – needs to be replaced. With the stylus with LH = 150 mm, the measuring range can be extended to 39 mm. With the stylus with LH = 200 mm, the measuring range can be extended up to 52 mm – this corresponds to the values of conventional contour measuring instruments.

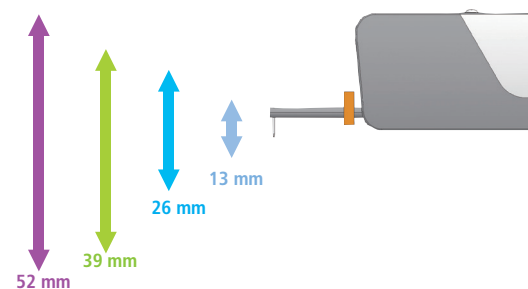

Efficient measurement of surface quality and contour thanks to hybrid detector

Hybrid detector simplifies automation processes

With simultaneous measurement of surface quality and contour using a hybrid detector

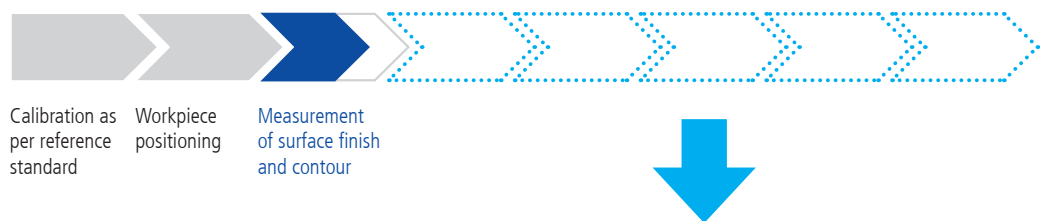

Increased efficiency thanks to reduced measurement times:

No need to switch between roughness and contour detector; no repositioning of the workpiece required.

When measuring with separate measuring instruments

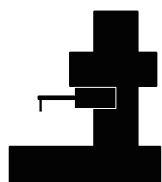

Contour measuring instrument

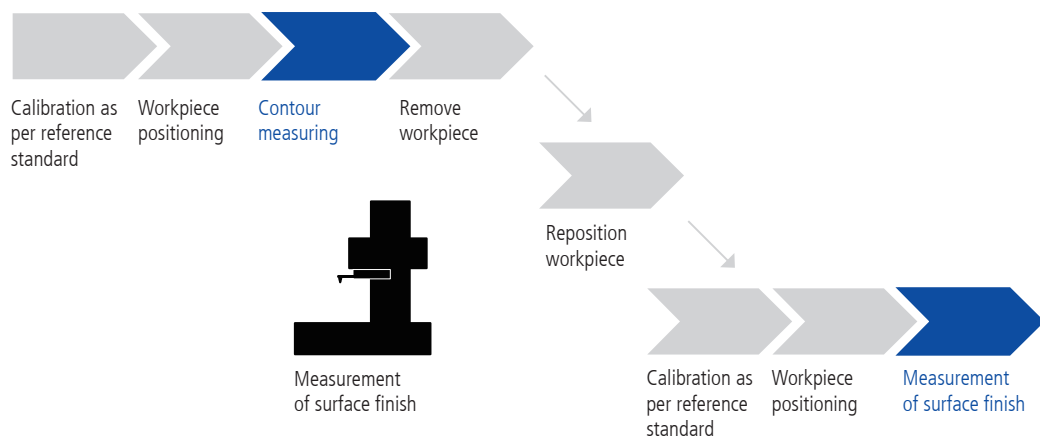

For measurements on a measuring instrument with stylus exchange

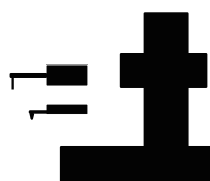

Combined measuring instrument for surface finish and contour

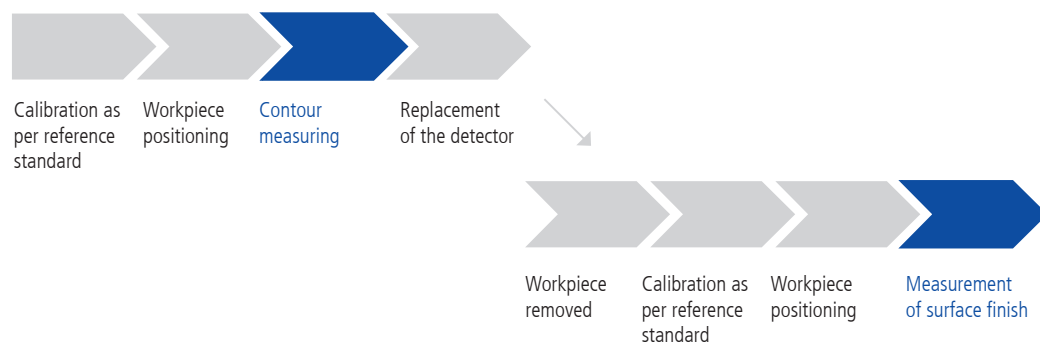

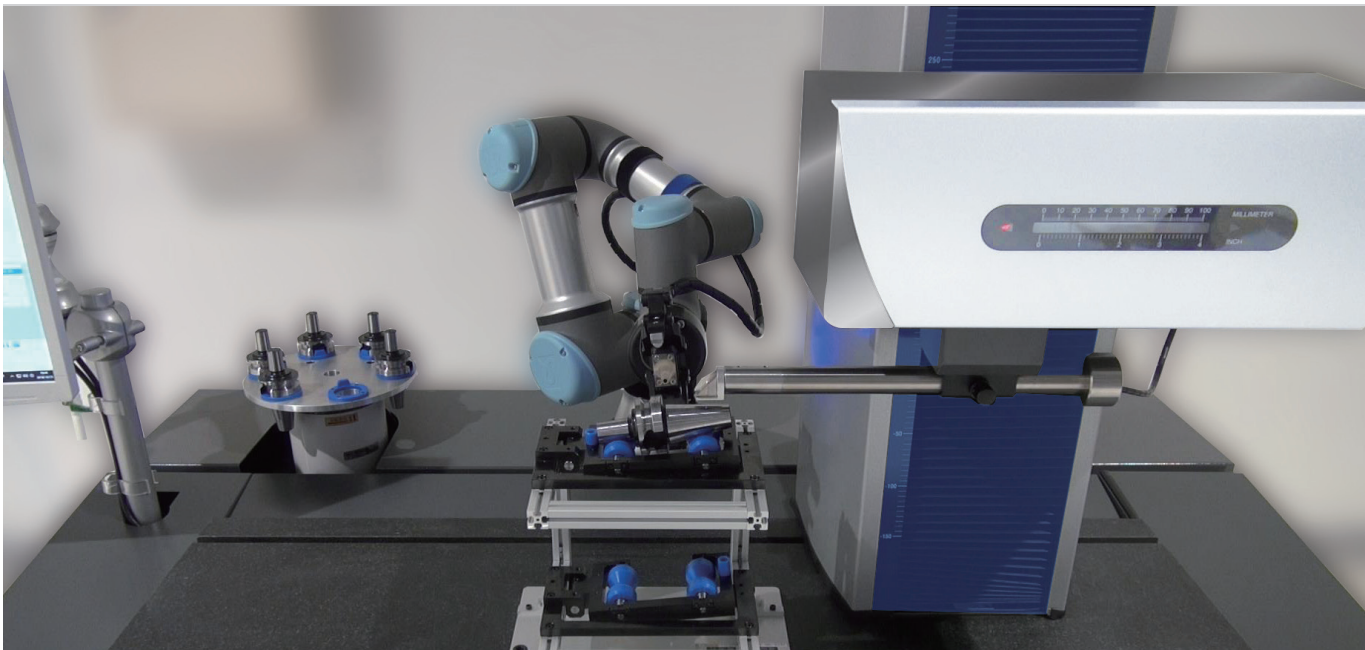

Safety mechanism to detect collisions between sensor and workpiece

The measuring instrument has a safety mechanism that stops the measuring process if the detector reports an imminent collision between stylus and workpiece. If a heavy load is applied to the direction of travel of the detector, the linear motor drive protects the instrument from damage.



Modular concept with detectors for every application

All systems expandable with all detectors

Roughness detector



- Measuring range (Z): 2000 μm
- Resolution (Z): 0.1 to 20 Nm
- Autostop sensor function in both directions
- 3D surface measurement with optional positioning tables or Y-drive and SURFCOM Map Software

Large measuring range for easy handling and flexibility for different requirements

Measuring range up to 2000 μm – 400 μm larger than conventional roughness sensors. The large measuring range saves the need for exact alignment of the workpiece.

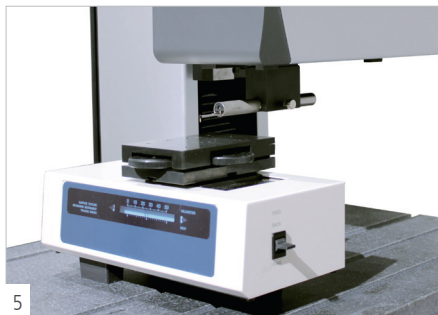
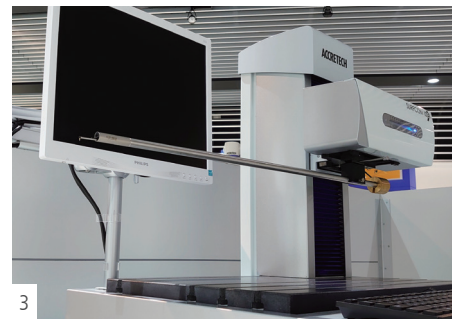
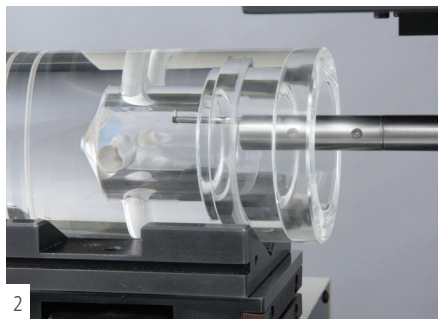

1. Detector can be swivelled by 90°
2. Autostop sensor function in both directions
3. Optional extension rod for very deep holes
4. 3D measurement of the surface quality. Y-axis drive for moving the sensor.
5. 3D measurement of the surface quality. Y-axis drive for moving the workpiece.

Detector for contour measurement



- Measuring range (Z): 60 mm
- Display accuracy (Z):
- $\pm (1.2+|2H|/100) \mu\text{m}$ ($20\text{ }^\circ\text{C} \pm 2\text{ }^\circ\text{C}$)
- $\pm (1.5+|2H|/100) \mu\text{m}$ ($20\text{ }^\circ\text{C} \pm 5\text{ }^\circ\text{C}$)
- Quick and easy replacement of the arm
- Continuous measurements up and down with T-shaped stylus
- Collision protection

Detector for high precision contour measurement



- Measuring range (Z): 60 mm
- Display accuracy (Z): $\pm (0.8+|2H|/100) \mu\text{m}$
- Quick and easy replacement of the arm
- Continuous measurements up and down with T-shaped stylus
- Software-supported automatic measurement force adjustment
- Collision protection

Quick and easy replacement of the stylus arm

Patented

Double magnet and V-groove with 3 positioning points keep the arm stable. Precise change of stylus arm position

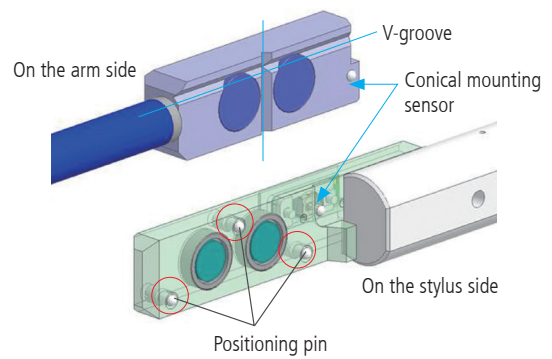

Mechanism for automatic measurement force adjustment

- Software-supported fine adjustment and control of the measurement force in increments of 2 mN
- Various combinations of arm and stylus can be used without weight adjustment
- Stylus is less likely to be scratched and damaged

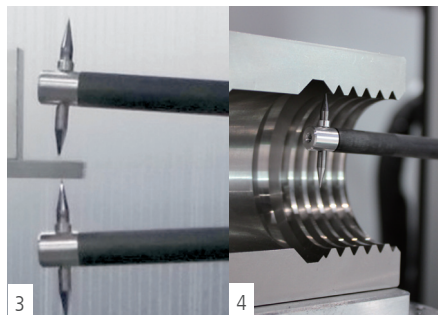
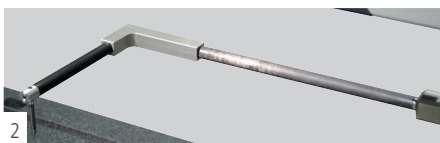
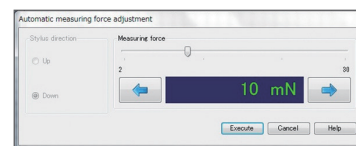

1. Optional 592 mm arm
2. Optional cranked arm
3. Measurement upwards and downwards
4. Use of a T-shaped stylus – Thickness measurement (left) / Diameter measurement (right)

Accurate measurement results with fluctuating temperatures

Patented linear motor drive with outstanding reliability Patented



Particularly reliable measurement results thanks to virtually vibration-free drive

In contrast to conventional spindle drives, no vibrations occur with the patented linear motor drive. Noise is thus minimised and extremely reliable measurement results can be achieved.

Real-time temperature correction ensures accuracy over a wide temperature range of 20 °C ± 5 °C

The temperature sensor in the linear motor drive corrects the expansion due to temperature changes. This real-time temperature correction ensures accuracy in a temperature range of 20 °C ± 5 °C. This range is therefore greater than the temperature range of 20 °C ± 1 °C or 20 °C ± 2 °C of conventional measuring instruments.

Measurement on a flatness standard

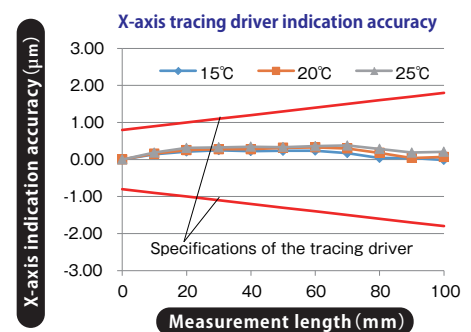
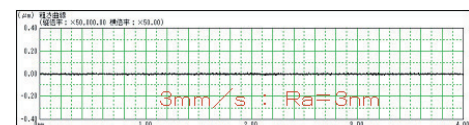

Low maintenance, newly developed travel axes

Conventional measuring instruments for surface quality and contour

- 1 With spindle drives, the lateral movement of the sensor is achieved by transmitting the rotary movement from the motor to the ball screw drive. (Oil needs to be topped up daily)
- 2 With linear motor drives, the lateral movement of the sensor is achieved with the help of magnetic force. (Oil does not need to be topped up daily)

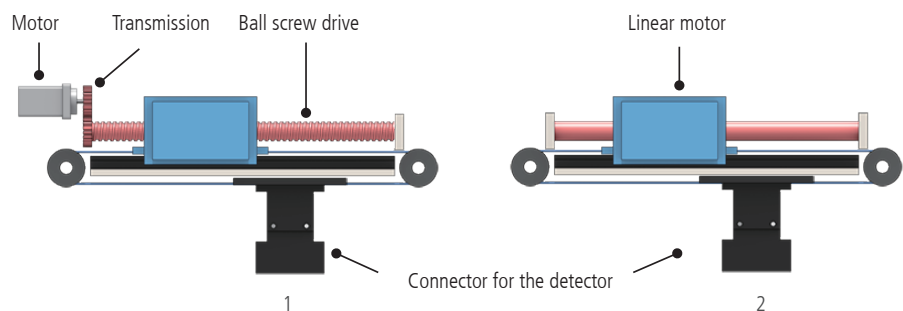

SURFCOM NEX

Linear motor drives do not require daily maintenance

The ball screw drive has been replaced by modern linear technology. The structure and material of the guide surface have also been adapted.



Innovative, highly robust column

With conventional measuring instruments, the column needs to be lubricated at regular intervals. The newly developed column of the SURFCOM NEX does not require any daily maintenance thanks to the innovative lubricant-free guide material and the special column coating material. The column is extremely robust, even when integrated into an automated system with continuous operation.

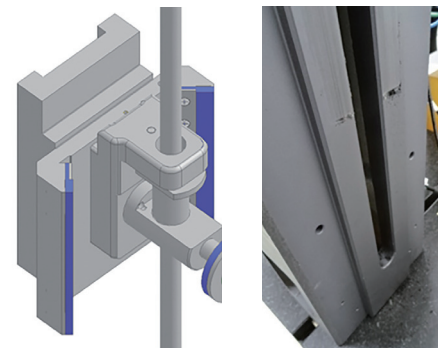

Lubricant-free guide material

Corrosion-resistant, lubricating coating

Time-saving preparation, measurement and cleaning

User-friendly operating concept

1 Size and position of the monitor are freely selectable.
Size: 24 inch (standard)
Position: left/right

2 Granite plate available in different sizes

3 Useful drawer for stowing accessories (optional)

4 Rear wall (optional)

5 Integrated measuring table for stowing PC, control unit, monitor and printer* (optional)

* An optional shelf is required in order to store the printer. A pull-out option with rails for the printer is also available

6 Vibration-damping table in DX design

7 New control panel ensures safe, efficient measurements

8 Practical storage box

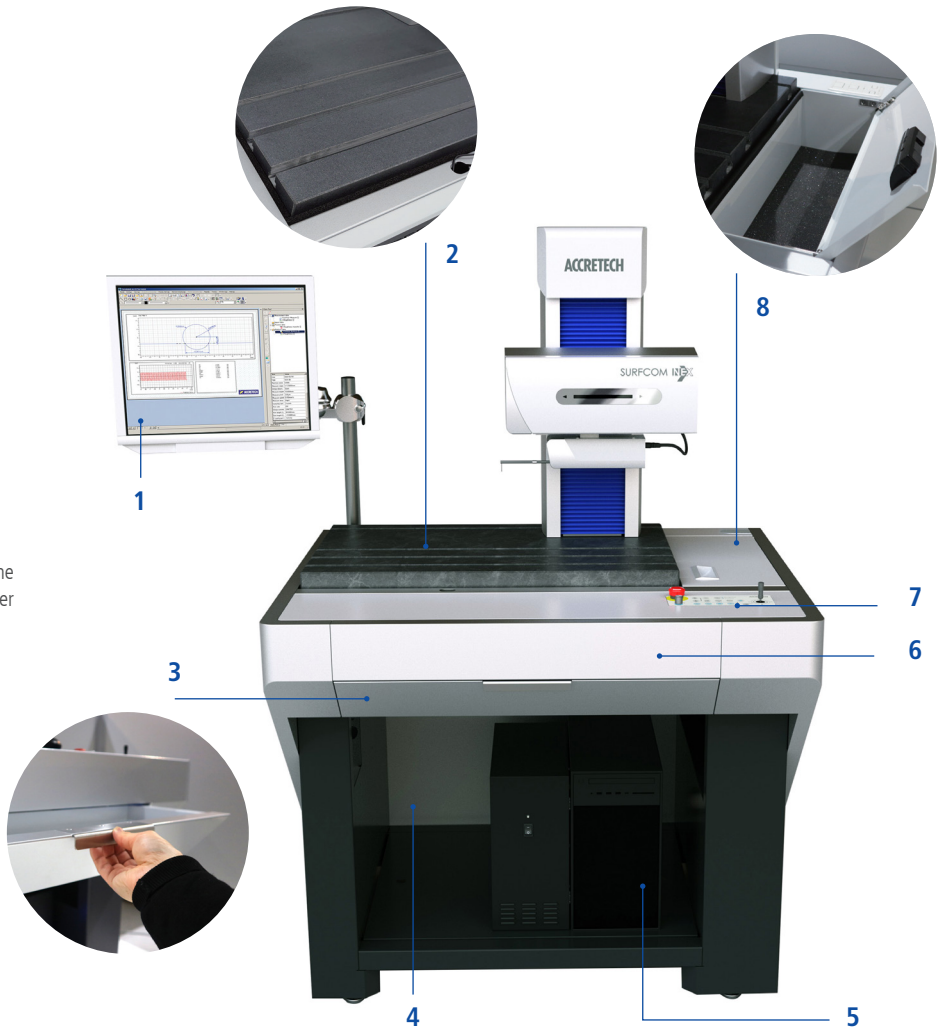

General separate measuring instrument of type SD*1

1 Granite plate available in different sizes

2 Compartment for sensor

3 New control panel ensures safe, efficient measurements



*1 The low-vibration table is optional for type SD.

Intuitive control panel ensures safe, efficient measurements

The knob controls the traversing speed on the X and C axes in real time. The lock button allows the control panel functions to be deactivated. In addition, the MID button allows intermediate points to be recorded during programming.

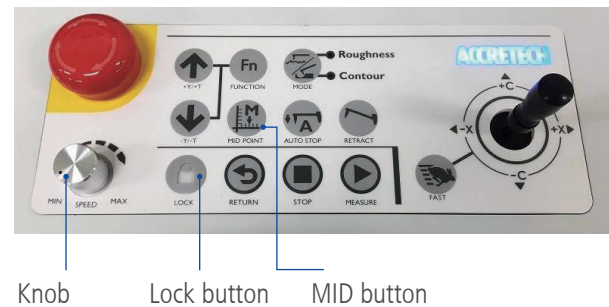

Knob Lock button MID button

Type DX is user-friendly and saves space

The type DX of the SURFCOM NEX series offers a measuring unit, a vibration-damping table, and a data processor in a single instrument.

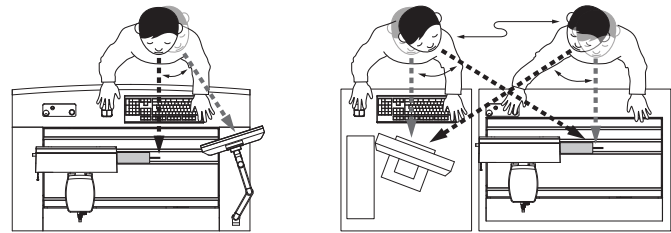

SURFCOM NEX Type DX

Conventional surface finish and contour measuring instrument/
SURFCOM NEX type SD

Integrated ACCTee measurement analysis software

The ACCTee software enables performance of the entire inspection process, from preparation (calibration) to analysis and printing of the results. A CNC programme for measuring multiple points and automatically outputting results can be easily set up.

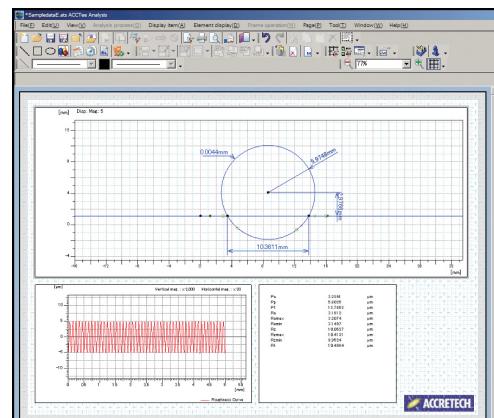

Model designation based on system configuration and selection

Product name

SURFCOM NEX

—

① Detector

② Type

③ Feed and granite plate

① Detector selection

	030	040	001	031	041	200	230	240	201	231	241
Hybrid detector											
Contour detector (standard)											
Contour detector (high precision)											
Roughness detector											

② Type selection

Type	DX2	SD2
Exterior view		

③ Selection of linear drive and granite plate

Linear drive	-10	-20
X axis traverse path (mm)	100	200
	•	•

Granite plate	-02	-03	-04	-05
Granite width x depth (mm)	700 x 450	•	•	
	1000 x 450			•
Measuring range C column (mm)	250	•		
	450		•	•
	650			•

Specifications

Measurement unit

Article				Model SURFCOM NEX (DX2/SD2)							
				12	13	14	15	22	23	24	25
Linear drive	X-axis (L: measuring length in mm)	Recording method		Linear scale							
		Straightness accuracy	with hybrid detector (µm)	(0.05 + 1.0 L/1000) (L: measuring length in mm) * with stylus with LH = 50 mm 2 (0.05 + 1.0 L/1000) (L: measuring length in mm) * with stylus with LH = 100 mm							
			with high precision contour detector (µm/mm)	0.8/100				2.0/200			
			with universal contour detector (µm/mm)	0.8/100				2.0/200			
			with roughness detector (µm)	(0.05 + 1.0 L/1000) (L: measuring length in mm)							
		X axis display accuracy (µm): horizontal ¹		±(0.8 + 1.0 L/100) (L: measuring length in mm) * Contour measurement with 100 mm drive ±(0.8 + 3.0 L/200) (L: measuring length in mm) * Contour measurement with 200 mm drive							
		Resolution (µm)		0.016							
Measuring stand	Column	Speed (mm/s)	Traversing speed	CNC		Max. 50					
			Measuring speed	Joystick		Max. 35					
	Base frame	Material	Gabbro								

Sensor

Hybrid detector	Measuring range	Z axis (mm): vertical	13 (with stylus with LH = 50 mm), 26 (with stylus with LH = 100 mm)						
	Roughness and contour	Recording method	High precision scale						
		Resolution (µm)	0.9 (full measuring range) *with stylus with LH = 50 mm 1.8 (full measuring range) *with stylus with LH = 100 mm						
		Display accuracy (µm): vertical	±(1.0+ 2H /100) (H: measuring height in mm) * with stylus with LH = 50 mm ±(1.5+ 2H /100) (H: measuring height in mm) * with stylus with LH = 100 mm						
	Stylus	for roughness and contour (LH = 50 mm)	Model	DM84071 (standard accessory NEX 2**)					
			Measurement force (mN)	0.75					
		for contour (LH = 100 mm)	Stylus material	Diamond					
			Stylus shape	R 2 µm/60 ° conical					
			Model	DM48775 (standard accessory NEX 2**)					
	Standard function	Downward measurements/collision protection mechanism/set-down function							
Universal contour sensor	Measuring range	Z axis (mm): vertical	60						
	Contour	Recording method	High precision scale						
		Resolution (µm)	0.04 (full measuring range)						
		Display accuracy (µm): vertical	±(1.2+ 2H /100) (H: Measuring height mm) * at 20 ± 2 °C ±(1.5+ 2H /100) (H: Measuring height mm) * at 20 ± 5 °C						
	Stylus	for contour	Model	DM45505 (standard accessory NEX *3*)					
			Measurement force (mN)	10 to 30 (manually adjustable)					
			Stylus material	Hard metal					
Function	Upward or downward measurements/collision protection mechanism/set-down function								
High precision contour detector	Measuring range	Z axis (mm): vertical	60						
	Contour	Recording method	Optical laser diffraction						
		Resolution (µm)	0.02 (full measuring range)						
		Display accuracy (µm): vertical	±(0.8+ 2H /100) (H: Measuring height in mm)						
	Stylus	for contour	Model	DM45505 (standard accessory for *4*)					
			Measurement force (mN)	2 to 30 (can be adapted with ACCFee software)					
Stylus material			Hard metal						
Function	Upward or downward measurements/collision protection mechanism/set-down function								
Roughness detector	Measuring range	Z axis (µm): vertical	1000						
	Roughness	Recording method	Differential inductance						
		Measuring range (µm)	6.4 to 1000						
		Resolution (µm)	0.1 to 20						
	Stylus	for roughness	Model	DM43801 (standard accessory NEX **1)					
			Measurement force (mN)	0.75					
Stylus material			Diamond						
Function	Upward or downward measurements/safety mechanism to detect the upper limit								

Other specifications

Power supply	Voltage (V), frequency (Hz)	Single-phase alternating current 100 to 240 V, 50/60 Hz						
	Power consumption (VA)	Max. 930						
Air supply	Supply air pressure (MPa)	0.45 to 0.7						
	Operating pressure (MPa)	0.4						
	Air consumption (L/min)	0.1 (max. 10)						
	Feed position	Model DX2: Main part bottom left/ Model SD2: Rear of the main part (with vibration-damping table)						
Supply air connection	Quick coupling for pipes with an outer diameter of 6 mm							
Ambient conditions	Temperature	Temperature for guaranteed accuracy (°C) ^{2,3}	20 ± 5 (temperature change rate ±0.5 °C/hour and 0.1 °C/measuring time)					
		Temperature for guaranteed operation (°C)	15 to 30					
		Storage temperature (°C)	5 to 40					
	Humidity	Guaranteed operating humidity (%)	40 to 80 (without condensation)					
Humidity during storage (%)		80 (without condensation)						

* 1 Not when using the roughness sensor

* 2 Guaranteed accuracy without workpiece deformation due to temperature change.

* 3 Display accuracy (vertical) for the universal contour sensor depends on the temperature range.

- Power supply and air supply and a connection hose are to be provided by the customer on delivery.

- Specifications are subject to change without notice when products are modified.

Dimensions and exterior view

DX2 Type	Dimensions (mm)					
	Width	Depth	Height	Height to the surface of the base frame	Height of the column	
Model	B1	T1	H1	H2	H3	
DX2	12	960	800	1489	855	634
	13	960	800	1689	855	834
	14	1261	800	1689	855	834
	15	1261	800	1909	855	1054
	22	960	800	1489	855	634
	23	960	800	1689	855	834
	24	1261	800	1689	855	834
25	1261	800	1909	855	1054	

Measuring range (mm)	
X-axis (Linear drive)	C-axis (Column)
-	-
100	250
100	450
100	450
100	450
200	250
200	450
200	450
200	650

Base frame (mm)	
Width	Depth
B2	-
700	450
700	450
1000	450
1000	450
700	450
700	450
1000	450
1000	450

Weight (kg)		
Weight of the measuring unit	Total weight ¹	Max. load weight
-	-	-
277	290	82
284	297	75
407	420	95
421	434	81
284	297	75
291	304	68
414	427	88
428	441	74

* 1 Weight includes PC, drive unit, monitor

Type SD2	Dimensions (mm)					
	Width	Depth	Height	Height to the surface of the base frame	Height of the column	
Model	B1	T1	H1	H2	H3	
SD2	12	700	636	1452	818	634
	13	700	636	1652	818	834
	14	1000	780	1675	841	834
	15	1000	780	1895	841	1054
	22	700	636	1452	818	634
	23	700	636	1652	818	834
	24	1000	780	1675	841	834
	25	1000	780	1895	841	1054

Measuring range (mm)	
X axis (linear drive)	C axis (column)
-	-
100	250
100	450
100	450
100	450
100	650
200	250
200	450
200	450
200	450

Base frame (mm)	
Width	Depth
B2	-
700	450
700	450
1000	450
1000	450
1000 [^]	450
700	450
700	450
1000	450
1000	450

Weight (kg)		
Weight of the measuring unit	Total weight ²	Max. load weight ³
-	-	-
119	132/217	81
126	139/224	74
206	219/442	54
220	233/456	40
126	139/224	74
133	146/231	67
213	226/449	47
227	240/463	33

* 2 Left-hand values ... weight includes PC, drive unit and monitor / Right-hand values ... weight includes PC, drive unit, monitor and optional accessories (vibration damping table, measuring stand, rack)

* 3 Max. load weight is the value with optional vibration damping table (12/13/22/23 ... E-VS-S319A, 14/15/24/25 ... E-VS-R16E)

Type DX2

12 13 14 15 22 23 24 25

Type SD2

12 13 22 23

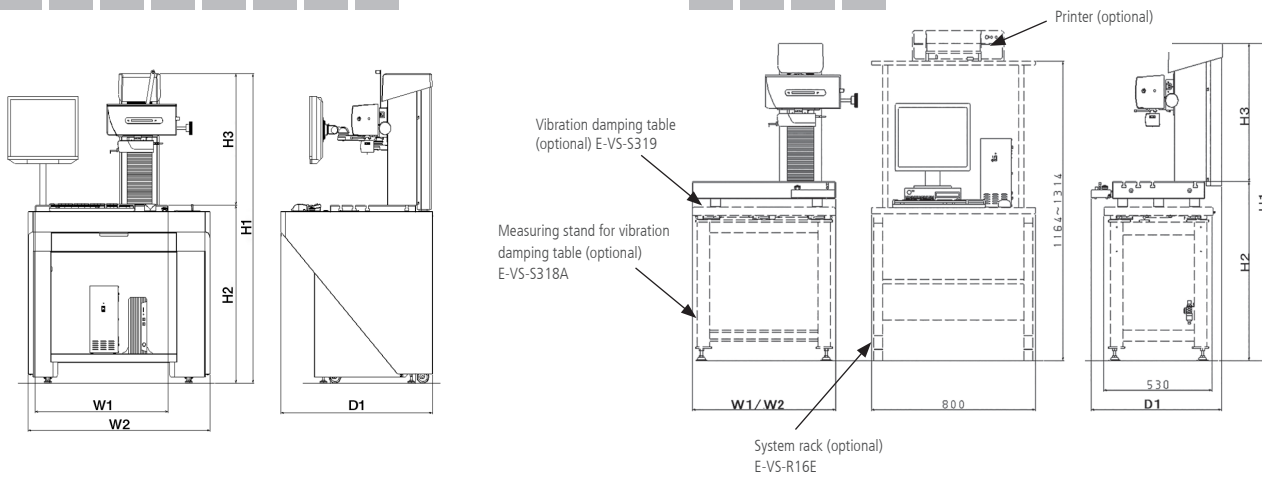

Type SD2

14 15 24 25

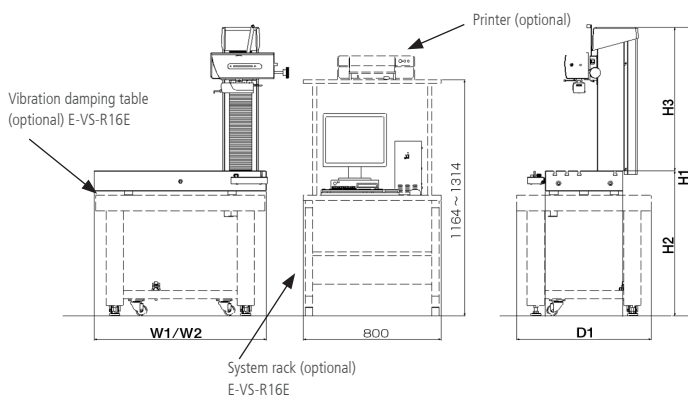

Accessories

Tilting device, linear drive E-CA-S164A

- Inclination: $\pm 15^\circ$
- Weight: 6 kg
- 100 mm/200 mm for all linear drives

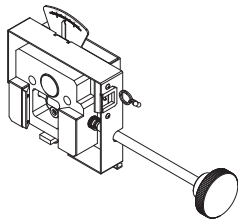

Detector holder E-DH-S336A

- A holder that allows the stylus to protrude further over the left end of the linear drive (for hybrid sensor)
- Max. protrusion: approx. 108 mm*1/158 mm*2 from the left end of the linear drive
- Max. measuring height: 18 mm less than with the standard holder
- Straightness: 0.3 $\mu\text{m}/100\text{ mm}$, 0.5 $\mu\text{m}/200\text{ mm}$ *1
0.6 $\mu\text{m}/100\text{ mm}$, 1.0 $\mu\text{m}/200\text{ mm}$ *2
- Measurement target*1: $R_a \geq 0.02\ \mu\text{m}$, $R_z \geq 0.2\ \mu\text{m}$

* 1 If standard stylus (LH = 50 mm) DM84071 is used.
* 2 If standard stylus (LH = 100 mm) EM48775 is used.

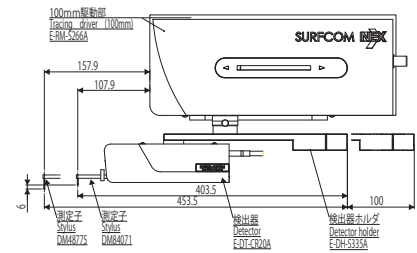

Accessories for type DX2

Drawer DM5186-S400

- Drawer on the front of the measuring stand for stowing accessories and small parts

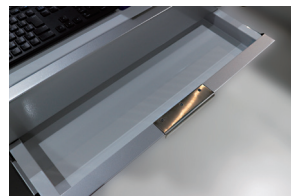

Shelf DM51816-S300

- Required for installation of the printer (optional) in the measuring stand
- The data processor and the drive unit can be positioned on the shelf, the printer below it



Rear wall

- This rear wall prevents dust from penetrating



Printer drawer with rails DM51816-S200

- With the above combination, the printer (optional) can be pulled out of the measuring stand
- With shelf DM51816-S300

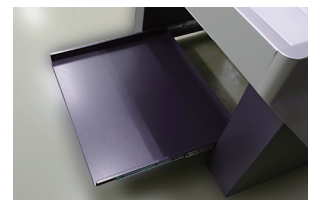

Accessories for type SD2

Vibration-damping table E-VS-S319A

- Natural frequency: 2.5 to 3.5 Hz
- Permissible load weight: 210 kg
- Supply air pressure: 0.45 to 0.7 Mpa
- Dimensions: 700 × 530 × 60 mm
- Weight: 29 kg
- Connection: quick coupling R 1/4 external thread
- With controller

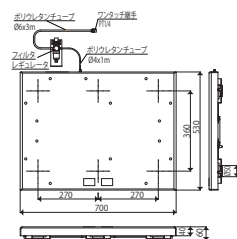

Vibration-damping measuring stand E-VS-R16E

- Natural frequency: V; 2.0 Hz, H; 2.2 Hz
- Permissible load weight: 260 kg
- Air supply: 0.45 to 0.7 Mpa
- Dimensions: 980 × 780 × 700 mm
- Weight: 190 kg
- Connection: quick coupling R 1/4 external thread
- With controller

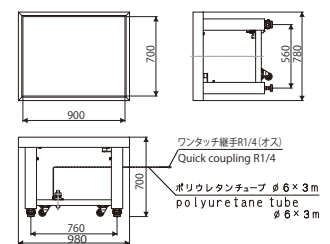

Measuring stand for vibration-damping table E-VS-S318A

- Dimensions: 670 × 490 × 643 mm
- For vibration-damping table E-VS-S319A

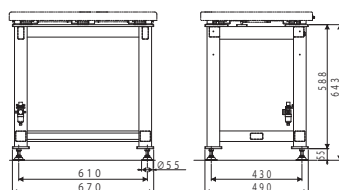

System rack E-DK-S24A

- Dimensions: 800 × 800 × (1070 to 1370) mm

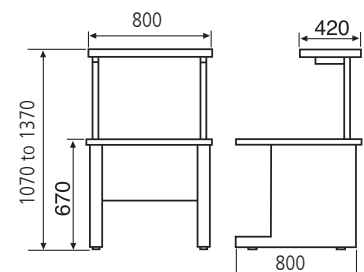











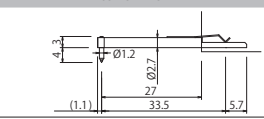

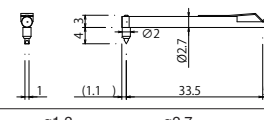

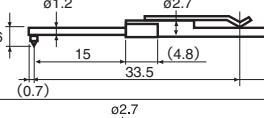

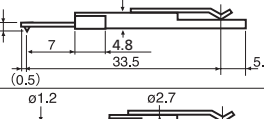

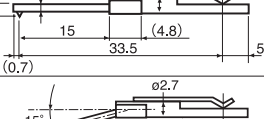

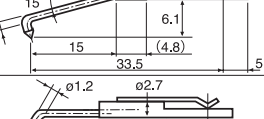

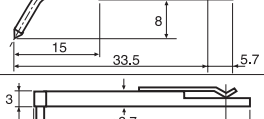

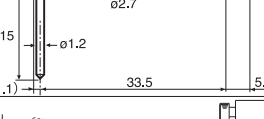

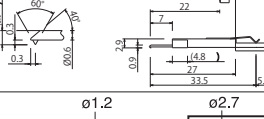

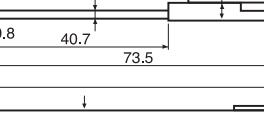
Stylus for hybrid Detector

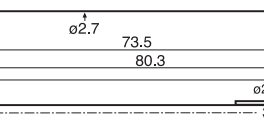
Roughness	Contour	Name	Model	Exterior view	Specifications	Remarks
●	●	Universal	DM48505		R 2 μm, 60° conical diamond, 0.75 mN	· Traverse path: 13 mm · For roughness and contour measurement
●	●	Highly rigid universal stylus	DM48471		R 2 μm, 60° conical diamond, 0.75 mN	· Traverse path: 13 mm · For roughness and contour measurement · Standard accessory for S-NEX 2**
	●	Highly rigid stylus for contours	DM48775		R 25 μm, 24° conical hard metal, 4 mN or less	· Traverse path: 26 mm · Only for contour measurement · Standard accessory
●	●	Highly rigid universal stylus	DM48636		R 2 μm, 60° conical diamond, 0.75 mN	· Traverse path: 26 mm · For roughness and contour measurement
	●	Highly rigid stylus for contours	DM48509		Ruby ball ø 1, 3.2 mN	· Traverse path: 32.5 mm · Only for contour measurement
●	●	Stylus for offset measurement	DM48511		R 2 μm, 60° conical diamond, 0.75 mN	· Traverse path: 13 mm · For roughness and contour measurement
	●	Stylus for offset measurement	DM48742		25 μm R, 24° conical diamond, 4 mN	· Traverse path: 26 mm · Only for contour measurement
●	●	Stylus for small holes	DM48513		R 2 μm, 60° conical diamond, 0.75 mN	· Traverse path: 13 mm · For roughness and contour measurement
●	●	Stylus for especially small holes	DM48514		R 2 μm, 60° conical diamond, 0.75 mN	· Traverse path: 13 mm · For roughness and contour measurement
●	●	Stylus for deep holes	DM48515		R 2 μm, 60° conical diamond, 0.75 mN	· Traverse path: 13 mm · For roughness and contour measurement
●	●	Stylus for fine contours	DM48588		5 μm R, 30° conical diamond, 0.75 mN	· Traverse path: 13 mm · For roughness and contour measurement
●	●	Stylus for straightness measurement	DM48774		R 2 μm, 60° blade-shaped diamond, 0.75 mN	· Traverse path: 13 mm · For roughness and contour measurement

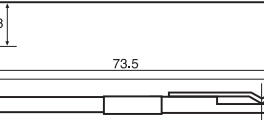
* Special styli are developed according to the customer's workpieces.

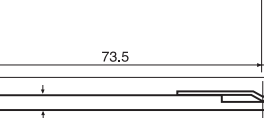

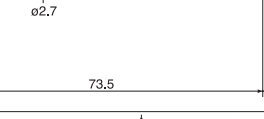

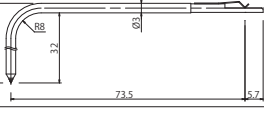
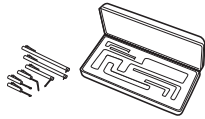



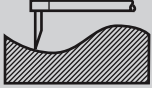
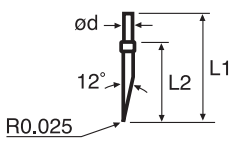

Standard accessory

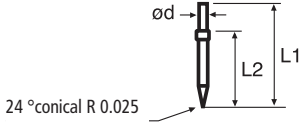
Roughness stylus (2 μm R)

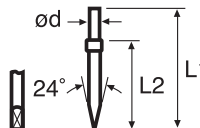
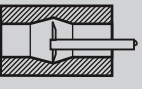
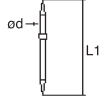
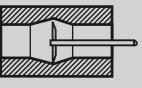
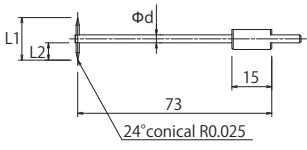
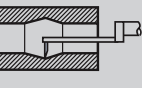
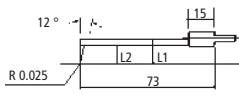
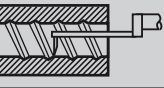
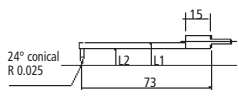
Measuring application	Model	Exterior view	Specifications	Remarks
 Universal	DM43801		R 2 μm, 60° conical diamond, 0.75 mN	<ul style="list-style-type: none"> · All alignments · Horizontal measurements possible · Standard accessory for S-NEX ***1
 Fine wires, blades	DM43802		R 2 μm, 60° blade-shaped diamond, 0.75 mN	<ul style="list-style-type: none"> · All alignments
 Medium-fine holes	DM43809		R 2 μm, 60° conical diamond, 0.75 mN	<ul style="list-style-type: none"> · All alignments · Horizontal measurements possible
 Especially fine holes, tooth flanks	DM43811		R 2 μm, 60° conical diamond, 0.75 mN	<ul style="list-style-type: none"> · All alignments
 Fine holes/narrow grooves	DM43812 ^{*1}		R 2 μm, 60° conical diamond, 0.75 mN	<ul style="list-style-type: none"> · All alignments · Horizontal measurements possible
 Bore base/conical surfaces	DM43813		R 2 μm, 60° conical diamond, 0.75 mN	<ul style="list-style-type: none"> · All alignments · Horizontal measurements possible
 Corners/tooth surfaces	DM43814 ^{*1}		R 2 μm, 60° conical diamond,	<ul style="list-style-type: none"> · All alignments · Horizontal measurements possible
 Deep groove/round groove	DM43815 ^{*1}		R 2 μm, 60° conical diamond, 0.8 mN	<ul style="list-style-type: none"> · Downward measurement · Large waveform distortion
 Tooth profiles, thread flanks	DM43818		R 2 μm, 60° conical diamond, 0.75 mN	<ul style="list-style-type: none"> · All alignments · Magnification: × 10,000
 Thin, large holes	DM43821		R 2 μm, 60° conical diamond, 2 mN	<ul style="list-style-type: none"> · Downward measurement · Sensitivity: 1/2 · Magnification: × 5000 · Large waveform distortion
 Low magnification, long holes	DM43822 ^{*1}		R 2 μm, 60° conical diamond, 3 mN	<ul style="list-style-type: none"> · Downward measurement · Sensitivity: 1/2 · Magnification: × 20,000
 Low magnification, corners	DM43824		R 2 μm, 60° conical diamond, 4 mN	<ul style="list-style-type: none"> · Downward measurement · Sensitivity: 1/2 · Magnification: × 2000
 Deep groove corners	DM43827		R 2 μm, 60° conical diamond, 4 mN	<ul style="list-style-type: none"> · Downward measurement · Sensitivity: 1/2 · Magnification: × 10,000
 Deep groove, O-ring slot base surfaces	DM43825		R 2 μm, 60° conical diamond, 3.4 mN	<ul style="list-style-type: none"> · Downward measurement · Sensitivity: 1/2 · Magnification: × 20,000 · Large waveform distortion
 Especially deep groove	DM43826		R 2 μm, 60° conical diamond, 4 mN	<ul style="list-style-type: none"> · Downward measurement · Sensitivity: 1/2 · Magnification: × 5000 · Large waveform distortion
Stylus set	DM43900-A	Stylus E-DT-SS01A·B E-DT-SSE01A用 	R 2 μm	Tip element: DM44026-A Stylus: DM43801, DM43811, DM43812, DM43814, DM43815, DM43822

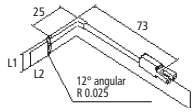
* 1 refers to the stylus/tip element set DM43900-A.

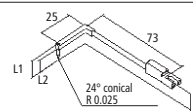

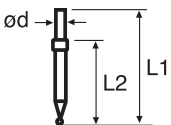



Stylus and arm for contour

Measuring application	Model	Exterior view	d	L1	L2	Adaptable arm	Remarks
Universal (single-sided cut) 	DM45501		3	60	52	DM83501 DM83517 DM83518	
	DM45502		3	34	26		
	DM45503		2	21	13		
Helical surface (conical) 	DM45504		3	60	52	DM83501 DM83517 DM83518	· Standard accessory for S-NEX *3*/*4*
	DM45505		3	34	26		
	DM45506		2	21	13		
Edge line (blade) 	DM45507		3	60	52	DM83501 DM83517 DM83518	
	DM45508		3	34	26		
	DM45509		2	21	13		
Upwards/downwards (conical) 	DM83502 ^{*1}		3	26	–	DM83501 DM83517 DM83518	· Measurement force: 10 mN or less
	DM83503 ^{*1}		3	32	–		
	DM83504 ^{*1}		3	44	–		
Small hole upwards/ downwards (conical) 	DM83534 ^{*3}		3	16	6.5	DM83521	· Measurement force: 10 mN or less
	DM83535 ^{*3}		3	9	3		
	DM83536 ^{*3}		2	5	1.5		
	DM83537 ^{*3}		1	2.4	0.7		
Small holes (single-sided cut) 	DM83522		–	12	9	DM83521	· Measurement force: 10 mN or less
	DM83523		–	8	5		
	DM83524 ^{*2}		–	4.5	1.5		
Small hole with helix surface (conical) 	DM83525		–	12	9	DM83521	· Measurement force: 10 mN or less
	DM83526		–	8	5		
	DM83527 ^{*2}		–	4.5	1.5		
Customary offset (single-sided cut) 	DM83528		–	12	9	DM83521	· Measurement force: 10 mN or less · Offset: 25 mm
	DM83529		–	8	5		
	DM83530 ^{*2}		–	4.5	1.5		
Helix surface offset (conical) 	DM83531		–	12	9	DM83521	· Measurement force: 10 mN or less · Offset: 25 mm
	DM83532		–	8	5		
	DM83533 ^{*2}		–	4.5	1.5		
High precision (ball) 	DM45522		3	60	52	DM83501 DM83517 DM83518	· Ruby ball 0.7
	DM45523		3	34	26		
	DM45524		2	21	13		
	DM45525		3	60	52	DM83501 DM83517 DM83518	· Ruby ball 1
	DM45526		3	34	26		
	DM45527		2	21	13		

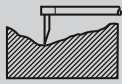
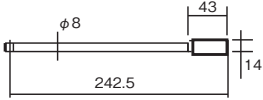
* 1: Master ball calibration unit for upwards/downwards measurement (E-MC-S97A) required.

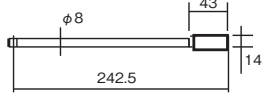
* 2: Master ball calibration unit for small holes (E-MC-S59D) required.

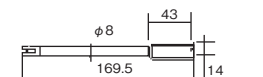
* 3: Calibration unit for upwards/downwards measurement of small holes (E-MC-S104A) required.

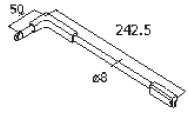
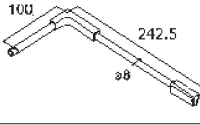
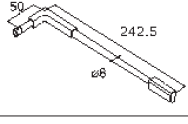
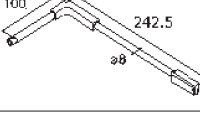
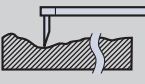
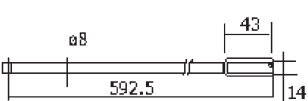
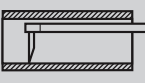
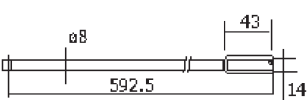
Measuring application	Model	Exterior view	Applicable stylus	Remarks
Universal 	DM83501		DM45501 DM45502 DM45504 DM45505 DM45507 DM45508 DM45522 DM45523 DM45525 DM45526 DM83502 DM83503 DM83504	<ul style="list-style-type: none"> S-NEX *3*/*4* Standard accessory Stylus diameter d = 3 mm Traverse path: 60 mm (when combined with left-hand stylus)
Internal surface 	DM83507		DM45503 DM45506 DM45509 DM45524 DM45527	<ul style="list-style-type: none"> Stylus diameter d = 2 mm Traverse path: 60 mm (when combined with left-hand stylus)
Small holes 	DM83521		DM83522 ~ DM83537	<ul style="list-style-type: none"> Traverse path: 60 mm (when combined with left-hand stylus)
Offset device 	DM83517		DM45501 DM45502 DM45504 DM45505 DM45507 DM45508 DM45522 DM45523 DM45525 DM45526 DM83502 DM83503 DM83504	<ul style="list-style-type: none"> Offset: 50 mm Supplied with additional weight Measurement force: 10 mN or less Stylus diameter d = 3 mm Traverse path: 60 mm (when combined with left-hand stylus)
	DM83518		DM45525 DM45526 DM83502 DM83503 DM83504	<ul style="list-style-type: none"> Offset: 100 mm Supplied with additional weight Measurement force: 10 mN or less Stylus diameter d = 3 mm Traverse path: 60 mm (when combined with left-hand stylus)
	DM83519		DM45503 DM45506 DM45509	<ul style="list-style-type: none"> Offset: 50 mm Supplied with additional weight Measurement force: 10 mN or less Stylus diameter d = 2 mm Traverse path: 60 mm (when combined with left-hand stylus)
	DM83520		DM45524 DM45527	<ul style="list-style-type: none"> Offset: 100 mm Supplied with additional weight Measurement force: 10 mN or less Stylus diameter d = 2 mm Traverse path: 60 mm (when combined with left-hand stylus)
Long test specimens 	DM83512		DM45501 DM45502 DM45504 DM45505 DM45507 DM45508 DM45522 DM45523 DM45525 DM45526	<ul style="list-style-type: none"> Offset: 100 mm Supplied with additional weight Measurement force: 10 mN or less Stylus diameter d = 2 mm Traverse path: 60 mm (when combined with left-hand stylus)
Long holes 	DM83514		DM45503 DM45506 DM45509 DM45524 DM45527	<ul style="list-style-type: none"> Moving range of lever: 120 mm Supplied with additional weight With mounted arm bracket Stylus diameter d = 3 mm Traverse path: 60 mm (when combined with left-hand stylus)

Quick-change attachment

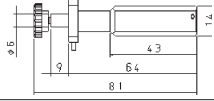
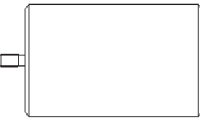
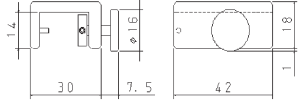
Measuring application	Model	Exterior view	Adaptable arm	Remarks
Quick-change attachment 	DM83506			<ul style="list-style-type: none"> Required for S-NEX *3*/*4* if using arms or stylus for linear versions (C1700-1710-2700-S1900-1910-2900) Additional weight required
Additional weight for quick-change attachment 	DM83505-S310 ¹ *3		0102800 0102805 0102801 0102806 0102802 0102807 0102804	<ul style="list-style-type: none"> S-NEX *3* Measurement force 10 mN or less
	DM83505-S307 ¹ *3		0102808	<ul style="list-style-type: none"> S-NEX *3* Measurement force 10 mN or less
	DM83505-S308 ¹ *3		0102810	<ul style="list-style-type: none"> S-NEX *3* Measurement force 10 mN or less
	DM83505-S305 ¹ *3		0102800	<ul style="list-style-type: none"> S-NEX *3* Measurement force 30 mN or less
	DM83505-S306 ¹ *3		0102801	<ul style="list-style-type: none"> S-NEX *3* Measurement force 30 mN or less
	DM83505-S309 ² *3		DM45528 DM45531 DM45529 DM45532 DM45530 DM45533	<ul style="list-style-type: none"> S-NEX *4* Measurement force 10 mN or less
	DM83505-S301 ² *3		DM45528 DM45529	<ul style="list-style-type: none"> S-NEX *4* Measurement force 30 mN or less
Arm bracket 	DM83538		0102808 0102810	<ul style="list-style-type: none"> Required for combination of long arm for linear versions 0102808, 0102810 and quick-change attachment

* 1: For information about stylus for arms suitable for the additional weights of the S-NEX*3*, please refer to our general catalogue for surface quality and contour measuring instruments.

* 2: For information about stylus for arms suitable for the additional weights of the S-NEX*4*, please refer to our general catalogue for surface quality and contour measuring instruments.

* 3: Contact us if you are using a stylus and arm combination other than * 1 and * 2.

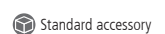

CNC tables for reduced workload

The CNC table, which can be retrofitted to the measuring instrument, can be controlled via the integrated ACCTee measuring software, and ensures easy teaching and playback.

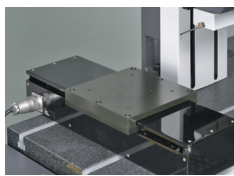

Y axis CNC table (100 mm)	
E-AT-S105A	
Traverse path	100 mm
Max. traversing speed	50 mm/s
Positioning accuracy	20 µm
Max. load	30 kg
Weight	Approx. 19 kg

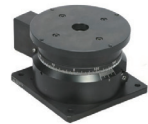

*

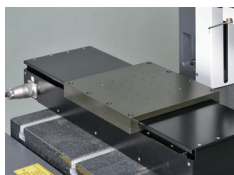

Y axis CNC table (200 mm)	
E-AT-S106A	
Traverse path	200 mm
Max. traversing speed	50 mm/s
Positioning accuracy	20 µm
Max. load	30 kg
Weight	Approx. 22 kg



*

θ-Axis CNC table (horizontal)	
E-AT-S107A	
Traverse path	360 °
Max. traversing speed	20 °/s
Positioning accuracy	0.03 °
Max. load	15 kg
Weight	Approx. 2.5 kg

θ-Axis CNC table (vertical)	
E-AT-S108A	
Traverse path	360 °
Max. traversing speed	20 °/s
Positioning accuracy	0.03 °
Max. load	5 kg
Permissible momentary load	5 mN
Weight	Approx. 3.2 kg

* The picture also shows an undertable (special article)

Devices

Name	Model	Exterior view	Orthogonal axis adjustment (mm)			Swivel adjustment		Tilt adjustment		Table size (mm)	Permissible load (Net weight) (kg)	Remarks
			X	Y	Z	Fine	Coarse	Fine	Coarse			
Adjustment stand	E-AT-S01D		50	50		8 °	360 °			ø150	20 (7)	Minimum measuring step 10 µm
Levelling adjustment stand	E-AT-S02A								±1.5°	80 × 110	15 (3)	
Adjustment stand	E-AT-S04A			±8			±3°			80 × 125	15 (8)	
Adjustment stand – Traversing movement in X-direction	E-AT-S08B		400							150 × 150	20 (25)	
3D fine adjustment stand	E-AT-S10B		50	50	30					76 × 76	1.6 (5)	Straightness: 0.03 mm
Single-axis precision fine-adjustment stand	E-AT-S11B			50						125 × 150	20 (4.9)	Straightness: 3 µm Min. measurement value: 10 µm
Rotary swivel fine adjustment stand	E-AT-S12B					±5°	360 °			ø 90	3 (0.58)	Min. measurement value: 5'
Tilt status	E-AT-S64B								±20°	60 × 120	10 (1)	Min. measurement value: 5'
Universal stand	E-WJ-S03A						360 °		±90°	ø 110	3 (2.5)	Adjustment, X/ Y direction

Name	Model	Exterior view	V-holder (mm)	Chuck (mm)	Vice (mm)	Bracket (mm)	Flat surface (mm)	Permissible load (Net weight) (kg)	Remarks
Vice open on both sides	E-WJ-S01B				Internal: 0 to 57 External: 38 to 105			5 (0.8)	· Contact us if you would like to use the tilt stand.
V-stand set	E-WJ-S02A		ø 1 to ø 150					(1.5)	· Supplied with workpiece tensioner
V-stand holder set	E-WJ-S04A		ø 12 to ø 120					(3)	· Two parts exclusively for T-slot clamp
Compact stand	E-WJ-S05A		ø 4 to ø 100					(0.4)	
Load plate	E-WJ-S06A						150 × 150 Angle plate	(1)	
Gear scroll chuck	E-WJ-R01C				AD: ø 2 to ø 79 ID: ø 20 to ø 90			(1)	
Iris chuck	E-WJ-R10B E-WJ-R378B				AD: ø 5 to ø 110 AD: ø 5 to ø 150			(3) (5)	· Production after receipt of order
Bracket set	JC-3					Height 40 to 60		-	
Ceramic load plate	E-WJ-S252A						300 × 300 Angle plate	(5.3)	· Production after receipt of order
	E-WJ-S234A						500 × 500 Angle plate	(15)	· Production after receipt of order

Standard accessory

Examples of device combinations

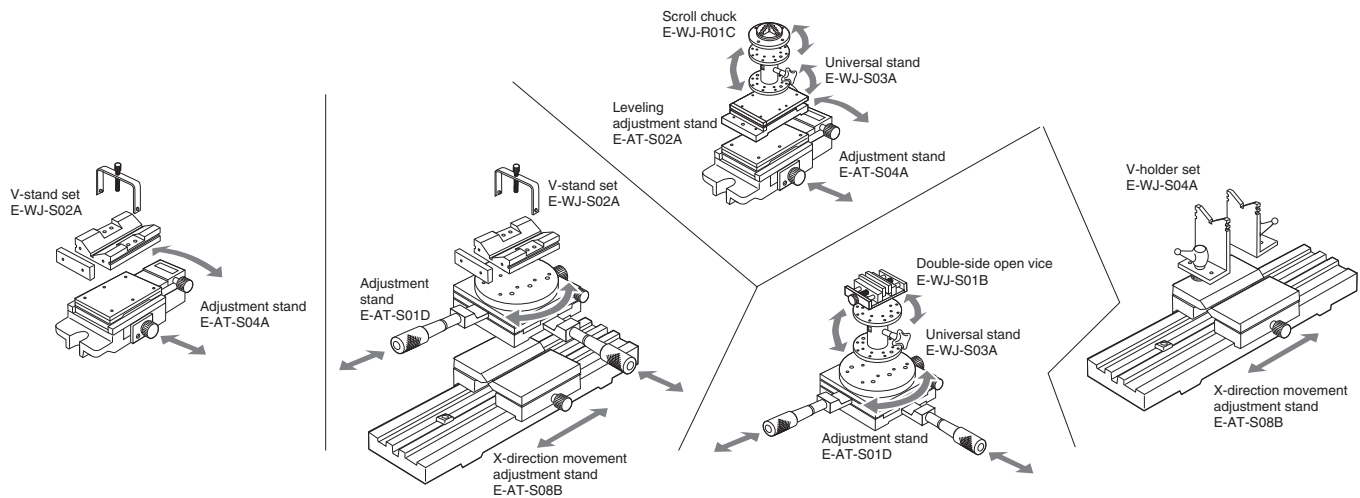

Calibration instruments

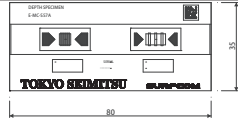
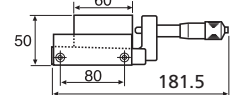
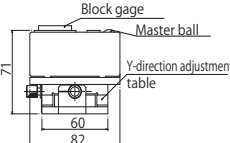
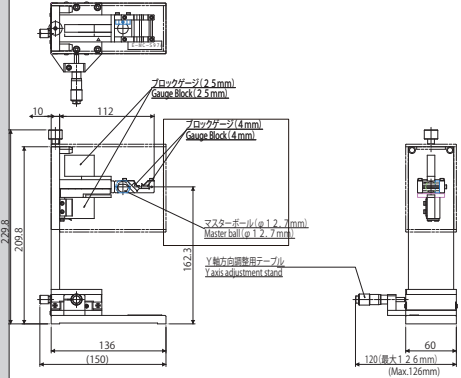
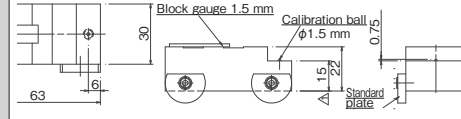
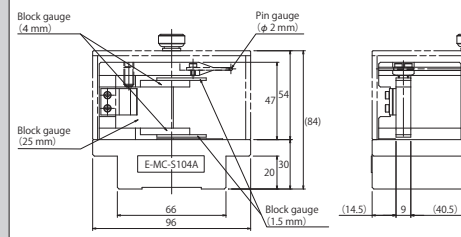
Name	Model	Exterior view	Specifications	Remarks
Reference specimen	E-MC-S109A E-MC-S24D		E-MC-S109A: For Japan (specification in millimetres) E-MC-S24D: Outside of Japan (specification in millimetres/inches) Calibration surface: Ra approx. 3.1 μm Stylus test surface: Ra approx. 0.4 μm Measurement value indicated	<ul style="list-style-type: none"> For sensitivity calibration and stylus testing Applicable for JCSS calibration and NIST calibration Standard accessory for S-NEX 2**
Reference specimen flatness difference	E-MC-S57A		Large measuring range: approx. 20 μm Small measuring range: approx. 2 μm Measurement value indicated	<ul style="list-style-type: none"> Standard accessory for NEX series and roughness system with linear designs For stylus sensitivity calibration and stylus testing Applicable for JCSS calibration
Magnification calibrator	E-MC-S50C		Narrow measuring range accuracy: 0 to 10 μm ± 0.1 μm Broad measuring range accuracy: 0 to 400 μm ± 1.0 μm	<ul style="list-style-type: none"> For magnification calibration
Master ball calibration unit	E-MC-S65B		Reference ball: ∅ 12.7 mm Measuring block: S-NEX 2** 10 mm *3*/*4* ... 25 mm	<ul style="list-style-type: none"> For measurements for which the stylus is facing downwards Standard accessory for S-NEX 2**/*3*/*4*
Stylus calibration unit for upwards/downwards measurement	E-MC-S97A		Reference ball: ∅ 12.7 mm Measuring block: 4 mm, 25 mm	<ul style="list-style-type: none"> For stylus for upwards/downwards measurement For S-NEX *3*/*4*
Master ball calibration unit for stylus for small holes	E-MC-S59D		Measuring block: 1.5 mm Reference ball: ∅ 1.5 mm	<ul style="list-style-type: none"> For measurements for which the probe is facing downwards, and stylus for measuring small holes For S-NEX *3*/*4*
Stylus calibration unit for upwards/downwards measurement for small holes	E-MC-S104A		Measuring block: 25 mm, 4 mm, 1.5 mm Testing pin: ∅ 2 mm	<ul style="list-style-type: none"> For stylus for upwards/downwards measurement for small holes For S-NEX *3*/*4*

Peripheral instruments

Name	Model	Exterior view	Specifications	Remarks
Water separator	L-WF-R08B			<p>Applicable for models: All models Dimensions: 100 mm (W) × 80 mm (T) × 280 mm (H)</p>
Oil separation	L-WF-R07B		Filtration: 0.1 μm	<p>Applicable for models: All models Dimensions: 100 mm (W) × 190 mm (H) Weight: 1.7 kg</p>
Air purifier set	L-WF-R11B		<p>Water separator L-WF-R08B, Oil separator L-WF-R07B Install on assembly plate</p>	<p>Applicable for models: All models Dimensions: 320 mm (W) × 170 mm (T) × 378.5 mm (H)</p>



Together with our partners, we can offer you a comprehensive sales and service network throughout Europe. Thanks to regional proximity, a service technician can come to your site without long waiting and travel times. If you have any questions please contact our central Metrology telephone number or email address directly from all European countries:



+49 711 25279000

Mon – Fri from 8:30 am to 5:00 pm



info@accretech.eu

Germany

ACCRETECH (Europe) GmbH
Felix Wankel Strasse 6
73760 Ostfildern
Email info@accretech.eu
Phone +49 711 25279000

Austria

ACCRETECH (Europe) GmbH
Landsberger Str. 396
81241 Munich, Germany
Email info@accretech.eu
Phone +49 89 250064200

Switzerland

Osterwalder Messtechnik AG
Sumpfstrasse 13
6312 Steinhausen
www.osterwalder-messtechnik.ch
Email info@osterwalder-zug.ch
Phone +41 417481919

Italy

ACCRETECH (Europe) GmbH
Via Giotto, 7
20032 Cormano
www.accretech.eu
Email info@accretech.eu
Phone +39 0223163291

France

ACCRETECH (Europe) GmbH
14 Chemin des Clos
38240 Meylan
www.accretech.eu
Email info@accretech.eu
Phone +33 476044080

United Kingdom

ACCRETECH SBS UK Ltd.
Unit 2, Leofric Court
Progress Way, Coventry CV3 2NT
www.accretech.eu
Email info@accretech.eu
Phone +44 2476651774

Ireland

JED Metrology Ltd.
21 Tolka Valley Business Park
Glasnevin, Dublin 11
Email sales@jed.ie
Phone +353 18307744

Denmark

ACCRETECH SBS UK Ltd.
Unit 2, Leofric Court
Progress Way, Coventry CV3 2NT
www.accretech.eu
Email info@accretech.eu
Phone +44 2476651774

Sweden

KMK Instrument AB
Regattagatan 8A
723 48 Västerås
www.kmk-instrument.se
Email info@kmk-instrument.se
Phone +46 21150160

Norway

ACCRETECH SBS UK Ltd.
Unit 2, Leofric Court
Progress Way, Coventry CV3 2NT
www.accretech.eu
Email info@accretech.eu
Phone +44 2476651774

Finland

ACCRETECH SBS UK Ltd.
Unit 2, Leofric Court
Progress Way, Coventry CV3 2NT
www.accretech.eu
Email info@accretech.eu
Phone +44 2476651774

Netherlands

ACCRETECH (Europe) GmbH
14 Chemin des Clos
38240 Meylan
www.accretech.eu
Email info@accretech.eu
Phone +33 476044080

Spain

Izasa Scientific S.L.U.
Plaza Europa 21-23
08908 L'Hospitalet de Llobregat
Barcelona
www.izasascientific.com
Email marketing@izasascientific.com
Phone +34 902203080

Portugal

Izasa Scientific, LDA
Avenida do Forte n° 6.
Edifício Ramazzotti - 3° piso 2.24
2790-072 Carnaxide, Lisboa
www.izasascientific.com
Email marketing@izasascientific.com
Phone +351 214247322

Poland

ACCRETECH – Tosei Hungary Kft.
Liget u. 3/2 3rd floor
2040 Budaörs, Hungary
Email info@accretech.eu
Phone +48 603530855

Hungary

ACCRETECH – Tosei Hungary Kft.
Liget u. 3/2 3rd floor
2040 Budaörs, Hungary
Email info@accretech.eu
Phone +36 23232224

Bulgaria

ACCRETECH – Tosei Hungary Kft.
Liget u. 3/2 3rd floor
2040 Budaörs, Hungary
Email info@accretech.eu
Phone +36 23232224

Romania

ACCRETECH – Tosei Hungary Kft.
Liget u. 3/2 3rd floor
2040 Budaörs, Hungary
Email info@accretech.eu
Phone +36 23232224

Slovakia

PRIMA BILAVČÍK, s.r.o.
9. května 1182
688 01 Uherský Brod, Czech Republic
www.merici-pristroje.cz
Email bilavcik@pirimab.cz
Phone +420 572632561

Slovenia

ACCRETECH – Tosei Hungary Kft.
Liget u. 3/2 3rd floor
2040 Budaörs, Hungary
Email info@accretech.eu
Phone +36 23232224

Czech Republic

PRIMA BILAVČÍK, s.r.o.
9. května 1182
688 01 Uherský Brod, Czech Republic
www.merici-pristroje.cz
Email bilavcik@pirimab.cz
Phone +420 572632561

Turkey

Yamer Endüstriyel Ürünler Ticaret Ltd. Sti
Karacaoğlan, 6172. Sk. No:8
35070 Bornova/Izmir
www.yamerend.com.tr
Email info@yamer.com.tr
Phone +90 2323420693

Serbia

ACCRETECH – Tosei Hungary Kft.
Liget u. 3/2 3rd floor
2040 Budaörs, Hungary
Email info@accretech.eu
Phone +36 23232224

We reserve the right to change the contents of this catalogue without notice, including product specifications, as products are updated. Some of our products are subject to the Foreign Exchange and Foreign Trade Act and require an export licence from the Japanese government. For questions regarding export of products and/or provision of technologies to customers located abroad, please contact ACCRETECH (Tokyo Seimitsu).



EUROPE

ACCRETECH (Europe) GmbH
Landsberger Str. 396, 81241 Munich, Germany
Phone +49 89 2500 64200, Fax +49 89 2500 64 210
info@accretech.eu
www.accretech.eu